

# Swing barrier gate

P Type

# User manual

## Table of Contents

1. Swing Gate Instruction.....	3
1.1 Brief Description.....	3
1.2 Main Features.....	3
1.3 Data Sheet.....	3
2. Swing Gate Dimension.....	4
2.1 Product Dimension.....	4
3. Swing Gate Structure and Working Mechanism.....	6
3.1 Mechanism System.....	6
3.2 Electronic System.....	6
3.3 System Operation.....	7
4. Swing Gate Installation and Testing.....	7
4.1 Installation.....	7
4.2 Testing.....	8
5. Equipment operating instructions.....	12
6. Common faults and analysis.....	12
7. Main board connection diagram.....	17

# 1. Swing Gate Instruction

## 1.1 Brief Description

Swing gate is a series machine to access control that manufactured for years in our company. The machine combined mechanism, electronic, microprocessor and all kinds of read & write technology. Working with different read & write device and protection device to realize smart control and management.

The machine made by stainless steel, well designed, anti-rust, stable and standard output electrical interface to connect read & write device, like barcode, IC card, ID card. In line with the fire management requirements, make sure evacuate people in time.

## 1.2 Main Features

1. Fault self-test and alarm functions, convenient user maintenance and using
2. Via the control board Built in a small dish, Programmable devices running status
3. Anti-Pinch mechanical structure, anti-bumps function, when the swing arm reset process meet resistance, within a limited time automatically stops the motor, the default delay after the reset again (until reset), and the force is very small ( $\leq 2\text{Kg}$ )
4. Break into protection function, when the gate signal is not received, the arm automatically locked
5. Relative with a variety of reader device attached, working when receive relay switch signal
6. Remote control and management by the management computer
7. Power-off arm Automatic open, turn on automatically closed, can meet fire safety requirements
8. Pinch function (bridge type four pairs of infrared optional)
9. Accurate logic judgment and infrared reset function (4 or 6 pairs of infrared)
10. Counting function (optional)

## 1.3 Data Sheet

Open/close time: 1-2 second/time (swing gate)

internal Structure: Steel frame structure

Working Volt : AC220V $\pm$ 10V , 50Hz

Passing speed : 30 persons/min

Input Interface : +12V Level signal or pulse width > 100ms DC12V pulse signal

Hydraulic shock absorbers can be freely adjusted for the return of the turnstiles

The open or close time of the turnstiles can be set.

Communication Interface: RS485

Communication Distance: less than 10 meters

Gates Open And Close Time: 0.8S

Driving Current :> 10mA

Working Noise: Below 65 decibels

Waterproof and dustproof: More than IP43

Working temperature: -15°C ~ 60°C

Relative humidity: less than 95%, non-condensing.

## 2.Swing Gate Dimension

### 2.1Product Dimension

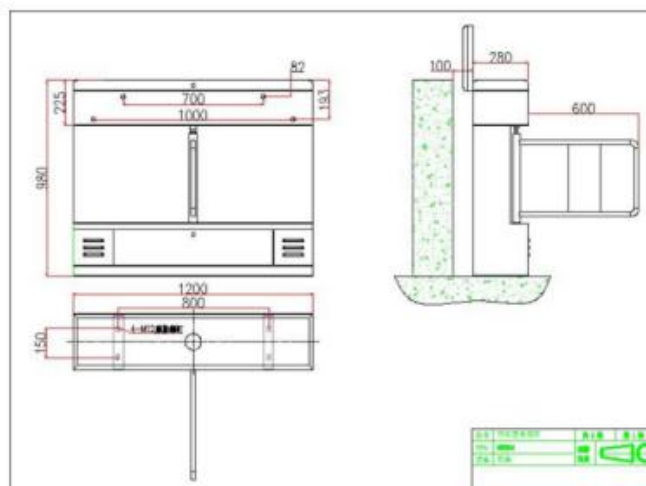

(1200x300x980)

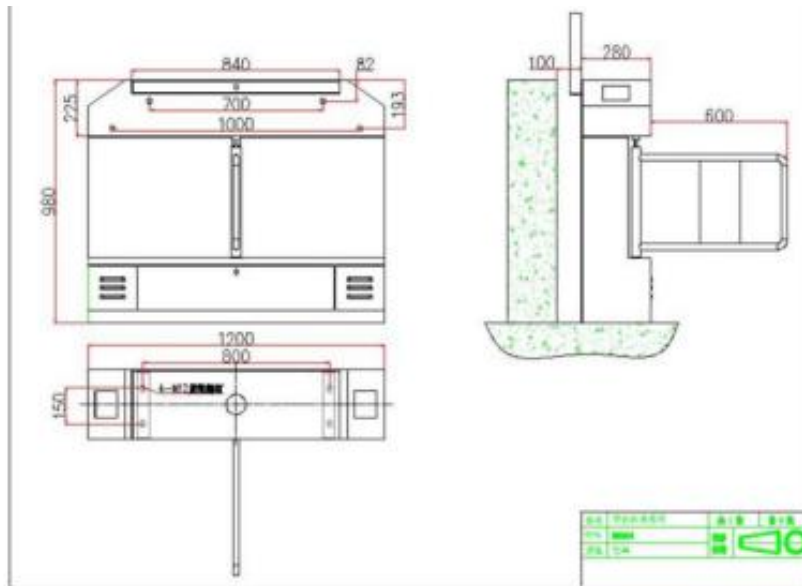

(1200x300x980)

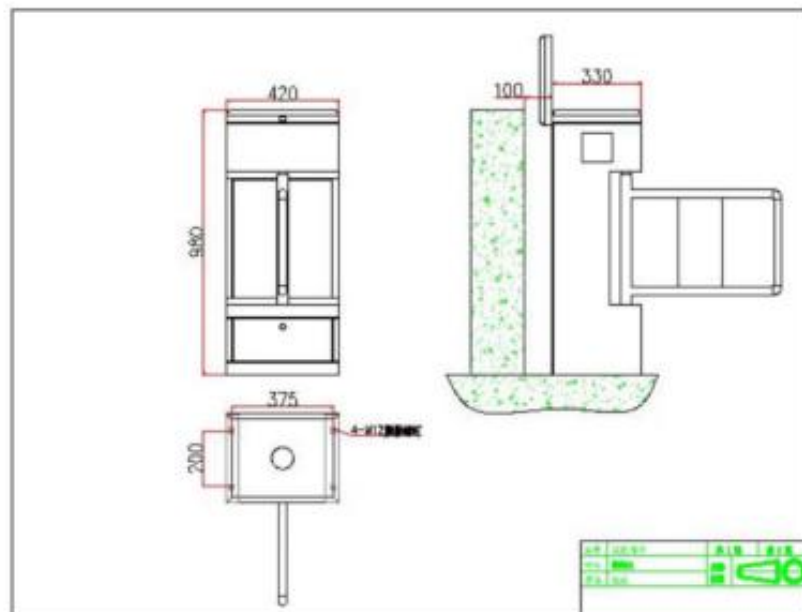

(420x330x980)

## **3.Swing Gate Structure and Working Mechanism**

### **3.1Mechanism System**

The mechanism system divided into 2 parts: hosing case and core. Install LED direction, read & write device, infrared sensor and so on; The core made by motor, arm, rack and so on;

### **3.2 Electronic System**

The electronic system made by reader, main board, infrared sensor, warning, position switch, open power and so on.

Reader: read and analyze information, send signal(open/close signal) to main control board.

- ◆ Main board: control center of system, it receives the signal from reader and infrared sensor, then process to issue order to LED direction, motor, counter, alarm;
- ◆ Infrared sensor: protect passengers from pinch;
- ◆ Direction indicator: showing state of the lane, and guide passengers get through in order;
- ◆ Alarm: if passengers trespassing, it will trigger alarm;
- ◆ Position switch: control the arm's moving position.

### **3.3 System Operation**

1) Turn on the power, system start in 3 seconds;

2) If reader read authorized card, beeper makes a sound to tell passenger to entry/exit;

3) Main board receive signal from reader and infrared sensor, and give order to LED direction indicator and motor, if direction indicator switch to green sign, in the meantime, machine makes a setting sound. Main board control motor, position switch control motor moving to open gate, allow people entry/exit;

4) Passenger pass according to LED indicator, infrared sensor sense the whole process and keep sending signals to main board until passenger passed;

5) If passenger pass without tap card or with unauthorized card, system won't allow passenger pass, and trigger voice alarm, (trespassing, please tap card) until passenger step out;

## **4. Swing Gate Installation and Testing**

### **4.1 Installation**

- ◆ Prepare tools before installation, and confirm all the parts;
- ◆ Known of components of system and mechanism before arrange works, start installation;
- ◆ Get the foundation ready and set machine in position;
- ◆ Make a room for screw, drill a hole and keep M12 anchor bolt in position;

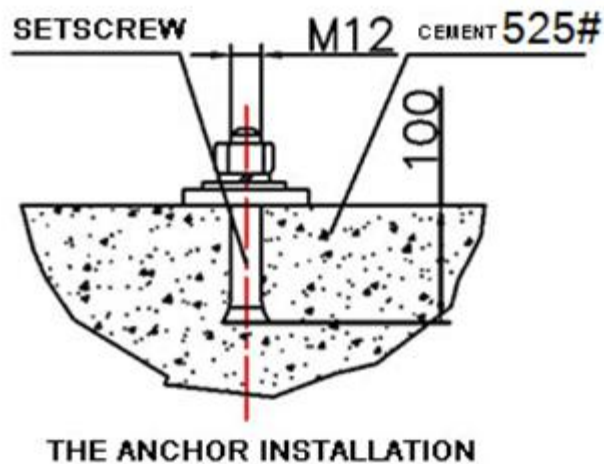

- ◆ Connect high voltage cable to low voltage cable with 3/4" PVC spool, and put in the cement.
- ◆ Set machine in the right spot of anchor bolt;
- ◆ Check system working state;
- ◆ Open case, choose one machine as a reference (best choose the middle one), put screw direct at anchor screw and tighten up a little for preparation;
- ◆ Open the side gate, and put screw direct at anchor screw and keep the referenced machine in line, repeat the steps if have many machines;
- ◆ Refer to drawing to connect cables, and earth wire for system protection;
- ◆ After check function work well, tighten up screw.

 :Warning

1. Put PVC spool no less than 60mm, reveal on the ground no more than 50mm, and bend at the exit to prevent from water;
2. Install machine, keep all in line;
3. Connect earth wire to protect system;
4. If use in outdoors, please set a 100-200mm height platform to damp-proof and a ceilings to water and sun proof;
5. Full check before put into use.

## 4.2 Testing

Check work normally, and testing!



## Swing Gate\ Flap Gate testing instruction

### Preparation for testing

Check cable connection according to drawing. Then turn on power for testing!  
Don't allow to put into use, if don't connect earth wire.

### Main board data setting instruction:

Turn on the power, the LED screen shows default state "Working mode"(Swing gate, open opposite, flap gate, 3 working modes), and data like, times of entry, exit.

There have 5 keyboards, menu, up, down, enter, back.

### Keyboard Instruction:

To enter menu setting:

Press "menu" to input password: "up-up-down-down-up-down". Input 6 passwords and press "enter" to get in menu page. Then press "up" "down" to choose, "enter" to any page to change data.

For example:

If need to change gate working mode: enter menu page, choose "gate working mode" \_ press "enter" (shows working state in current)\_ press "enter" to change page\_ press "up" or "down" to choose right working mode\_ press "enter" to done\_ after setting success, press "back" (if don't press "back", system will log out automatically in 15 seconds).

### A. System menu instruction:

1. "Entry/exit direction setting":  
Set machine left is entrance or exit; The right is entrance or exit.
2. "Entry/exit pass setting"  
Set machine can pass in both side (entry and exit).
3. "Working method"  
Set open by infrared or RFID card.
4. "Entry/exit memory setting"  
Open or close entry/exit if have memory, in general, use in tap card, one passenger doesn't pass when tap card, then the other should tap again or not. "Not allow" the first one tap card, the second one need tap as well. "Allow" how many people pass when how many tap cards.
5. "Entry/exit opening time"  
Set open, if no one pass, the machine close automatically.
6. "Counting reset"  
Clear pass records and recount.
7. "Machine NO."  
Main control board's NO. In most of case, no need to set.
8. "Machine information"

Show information of LED main control board, like type, model and so on.

9. "Machine type"

type: flap gate, swing gate (one arm), swing gate (open opposite) ; Default type is flap gate.

10. "System Initialization"

Initialize the control board parameters, the initialization is successful, the control panel parameters to restore the factory settings

11. "Left pass voice"

Set the voice that the handset needs to play when passing from the left. Such as: from the left pass, the gates speaker play "Welcome"

12. "Right pass voice"

Set the voice that the handset needs to play when passes from the right. Such as: the right when the passage of time ,the gate speaker play "all the way safe."

13 "Test voice"

Automatically play the control panel voice, automatically exit after play

14 "Motor speed"

Used to set the motor speed, the value smaller, then the speed slower

15 "Maximum motor running time"

Set the maximum time for the motor to run at one time (the control panel is faulty due to external detection Or other original no signal) to prevent the motor has been idle, the default is 10S

16 "Allow infrared sensor overlap time"

Set the time to allow two infrared sensor stops at the same time, Due to the short distance between some gate infrared sensor (such as left infrared sensor and anti-pinch close), To prevent the body at the same time blocking the two infrared sensor, voice will be false positives

17 "Delayed closing time"

Used to set how long to close the gate after People pass through the gate, Unit for the "second", the default is 0, no delay, that is, after people pass the door close immediately

18 "Swing gate power switch set"

When the gate is turned off, the gate is opened and is not valid in the flap barrier gate mode

19 "Illegal break into operation"

Set the illegal entry into the barrier gate, the corresponding action of the brake. Can be set to illegal entry when the gate automatically shut down or not action

20 "Motor brake setting"

Whether to start the turnstile barrier brake function

21 "Gates Normally open set"

This parameter is used to set the open gate signal more than how many seconds, the system into the normally open state, give the gate of the open gate signal if it is a continuous signal, gate will always be open, how long the signal continues, then the gates open same time

22. "Gates test"

Repeated gate opening brake test, mainly used to test the stability of the control panel and aging test, the user does not need to use

Remark: 1. The peripheral device may not be added to the system without permission

2. If the test results are not consistent with the described functions during debugging, refer to the common faults and exclusion section

## 5. Equipment operating instructions

- 6.1 Before put into use ,the barrier gate must be through the function of debugging firstly,Debugging normal before put into use;
- 6.2 When the device is powered on, it is forbidden to stand in the channel;
- 6.3 Pedestrian card access, the direction indicator mark is not converted to green, is forbidden into the channel;
- 6.4 When pedestrians pass through the channel, do not stay in the middle of the channel for a long time;
- 6.5 Through the gateway, do not crowded, between people should maintain a certain distance;
- 6.6 Forbid do not read the card, and quickly pass the gate
- 6.7 It is advisable to identify the instructions of this machine at the conspicuous work of the equipment,guide the passers safe and orderly through the gate channel
- 6.8 When the equipment is not working need to properly manage, is strictly prohibited, shake the device
- 6.9 When the device is in the closed state, it is strictly forbidden to push or hit the gate

- Warn:** 1. Do not use the barrier gate when lightning strikes to prevent damage to the unit
- 2.To ensure that the system to protect the reliable access to prevent personal injury

## 6. Common faults and analysis

Basic concept:

A、 Limit photoelectric switch: ( barrier gate for position control) a total of three lines, of which two lines power inputIn, brown: + 12V, blue: GND and 1 signal output when the sensor head touches the magnet Or metal objects (sensing distance 2-4mm) the output +12 V, otherwise 0V



B、 Motor: DC24V DC gear motor, the normal working time load current is about 300mA,  
The load current is less than 1.2A



C、 Cylindrical photoelectric switch: (alarm and anti-clip signal detection with the same) consist of the transmitter and receiver, The transmitter has 2-wire power input (brown: +12 V, blue: GND), power supply normal indication The light is on; the receiver has two lines of power input (brown: + 12V, blue: GND) and one Line signal output (black line), when the person through the area, that is, when the signal is off the signal output indicator light on, out put +12 V, otherwise 0V



D、 Cylindrical reflective photoelectric switch: (role with the above) a total of three lines, of which two lines power transmission In, brown: + 12V, blue: GND and 1 line signal output (black), when people pass reflected Type photoelectric switch (reflection distance of 10-20mm) output +12 V, otherwise 0V



1. After power on the brake arm back and forth after the rotation or open gate is not limited

1) To sure whether the limit photoelectric switch is subject to strong light exposure (generally refers to the outdoor installation and commissioning)

2) Test limit photoelectric switch:

A、 Check the zero, left open in place, right open in place the limit photoelectric switch is powered! Check the terminal for loose or bad contact;

B、 With the iron on the front of the photoelectric switch (pay attention to close to the detection surface), see the photoelectric switch above the light whether bright, if not light that photoelectric switch is bad, if the light on, then appropriate adjustment of the photoelectric switch position

3) Check whether the connection between the photoelectric switch and the motherboard is reliable

4) Limit photoelectric switch and wiring are normal, then motherboard damage

2. After give valid open gate signal barrier gate no action

1) The motherboard indicator light is normal, when give the effective opening signal, the indicator light will become a green arrow, the barrier gate no action:

Detection method: Check the motor cable whether connected well, if the motor cable has a good connection, using hand touch motor tail, check the motor whether rotating, if rotating means that the motor line reversed, re-take the motor line positive and negative, if the motor does not turn, Directly connected to the motor with a 24V power supply, if the motor is still not turn, it shows that the motor is damaged, if the motor has turned, indicating that the motherboard motor driver chip with problems, contact us to replace the motherboard

2) The motherboard lights are not bright, check whether the switch power to the motherboard connection is normal, if there is 24V terminal voltage on the motherboard, check whether the fuse is normal, if the fuse is damaged, replace the fuse, if the fuse is normal, that the motherboard damage, Replace the motherboard

3、 The gate is not reset after the gate is opened or Reset immediately after opening

The gate is not immediately reset after people pass, gate close with a certain period of time delay, indicating that the work is not normal with infrared sensor

Detection method : First check the cylindrical photoelectric switch and whether the pass; a signal output on the motherboard left infrared sensor or right infrared sensor light will be bright, otherwise the motherboard is damaged; check whether the motherboard parameters set to bring memory; When the gate open, people access to the channel, the gate immediately reset, indicating that the left and right infrared sensor reversed, check the connection with the motherboard

4、 After the power off the gate is not open state

1 ) Detection of dry battery voltage (no less than DC9V)

2 ) Check the line is loose or desoldering, the battery terminal to detect the voltage output (not less than DC9V), otherwise the control panel is damaged

5、 After the power off swing arm is not limited and power turn on the swing arm reverse

1 ) Detection of dry battery voltage (no less than DC9V)

2 ) Respectively to detect left and right open position in place the photoelectric switch and motherboard

3 ) Swing arm reversal, The motor line is reversed

6、 When online use cut off cylindrical photoelectric switch then barrier gate open

1) The machine transferred into the infrared sensor gate mode, and into the menu to change the way the gate switch to card open mode

7、 Online-use open gate, two gates are not synchronized

Check the problem if it is caused by cable joint loose or invalidation, and check if cable connect in right order.

8、 After swipe card gate open, barrier gate open wait until controller closed

Entry the menu transfer turnstile barrier open gate signal into high level open gate

9、 Takes long time to close the gate after turnstile barrier open

1 ) No person pass: Check whether the entry and exit times are set too long (see the system parameter setup instructions)

2) When people pass: check anti-folder infrared photoelectric switch, black output signal terminal is 12V voltage (normal 0V), otherwise photoelectric switch transmitter or receiver damage

10、 Alarm when people pass through the open channel

1)Check whether the entry and exit times are set too short (see system parameter setup instructions);

2)Check out whether the infrared photoelectric switch is wrong, that is wrong to enter the photoelectric switch signal received out, and out of the wrong signal to the incoming, so cause false alarm



# 7.Main board connection diagram

