

SLIDING GATE OPERATOR **INSTRUCTION**

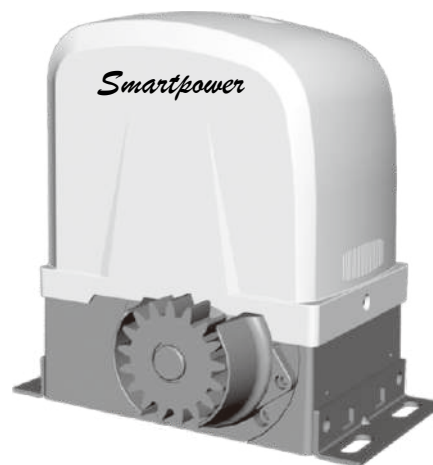

SP SLG 800B MG (Metal)

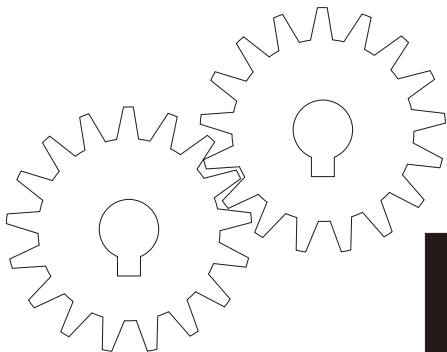

PY4. 21







**PLEASE READ THE MANUAL CAREFULLY
BEFORE INSTALL AND USE**

WARNING TO THE INSTALLER GENERAL SAFETY OBLIGATIONS

- 1) CAUTION! For personal safety it is important to follow all the instructions carefully. Incorrect installation or misuse of the product may cause serious harm to people .
- 2) Keep the instructions in a safe place for future reference.
- 3) This product was designed and manufactured strictly for the use indicated in this document. Any other usage not expressly indicated in this Document, may damage the product and/or be a source of danger.
- 4) BS accepts no responsibility due to improper use of the automatic machine (opener) or use other than that intended.
- 5) Do not install the machine in an area subject to explosion hazard. Inflammable gasses or fumes are a serious safety hazard.
- 6) BS will not accept responsibility if the rules of good workmanship are disregarded in installing the closing elements to be motorised, if any deformation occurs during use of the said elements.
- 7) Before carrying out any work on the system, turn off the electricity supply.
- 8) The safety devices (e.g. photocells, sensitive edges, etc...) may be used to prevent any potential risk in dangerous areas where the moving mechanism is located , such as crushing, dragging, or shearing.
- 9) BS accepts no responsibility regarding safety and correct operation of the machine, should components made by manufacturers other than we be used in the system.
- 10) Do not make any alterations to the components of the automatic machine (opener and accessory).
- 11) The installer must supply full information regarding operation manual of the system in the event of any emergency and provide the system user with the "INSTRUCTION" included with the product.
- 12) Do not allow children or other people to stand near any moving part of the opener or door construction while in operation.
- 13) Keep transmitters away from children to prevent the machine from being activated accidentally.
- 14) The user must refrain from attempting to repair or adjust the system personally and should only contact professional personnel .
- 15) Frequently examine the installation, in particular check cables, springs and mountings for signs of wear, damage or imbalance .Do not use if repair or adjustment is needed since a fault in installation or an incorrectly balanced door may cause injury.

- 16) This appliance is not intended for use by persons (including children) with reduced physical, sensory or mental capabilities, or lack of experience and knowledge, unless they have been given supervision or instruction concerning use of the appliance by a person responsible for their safety.
- 17) If the supply cord is damaged, it must be replaced by the manufacturer, its service agent or similarly qualified persons in order to avoid a hazard.
- 18) Disconnect the supply when cleaning or other maintenance is being carried out, if the appliance is automatically controlled.
- 19) The temperature range marked on the drive should be suitable for the location.

1. Introduction

<p>CONCISE Complete kit</p>	 <p>Release key</p>	 <p>Limit magnet/ Bracket</p>	 <p>SP SLG 800B ML</p>
 <p>Transmitters</p>	 <p>Base plate</p>	 <p>Accessories</p>	

1.1 Dimension

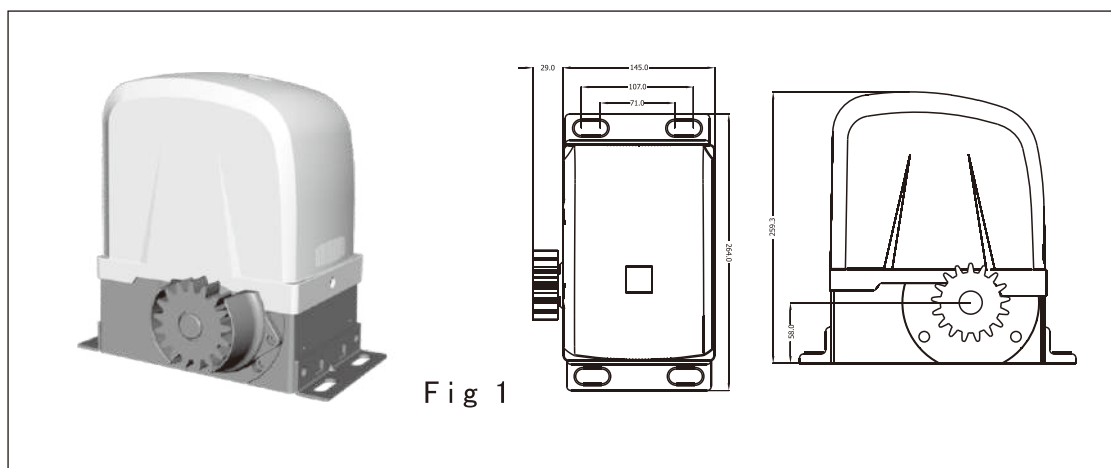

- * Built-in control board.
- * Terminals for Push button, Photocell, Alarm lamp.
- * Auto-closing is available, time delay is adjustable.

1.2 Technical Specifications

Power supply	230V 50Hz
Motor power	AC260W
Absorbed current	3A
Motor rotational speed	1400r/min
Thermal protection on motor winding	120°C
Ambient temperature	-20°C ~ 55°C
Max weight of gate	700Kg

2. Installation

- * Before using the machine, check power supply, grounding, voltage, etc.
- * Check whether it is connected according to the demand of wiring diagram.
- * The gate should be pulled easily and smoothly manually when the worm gears are released.
- * The worm gears will be coupled before power on.
- * The product must be installed by professional person.

2.1 Example of a sliding gate operator installed

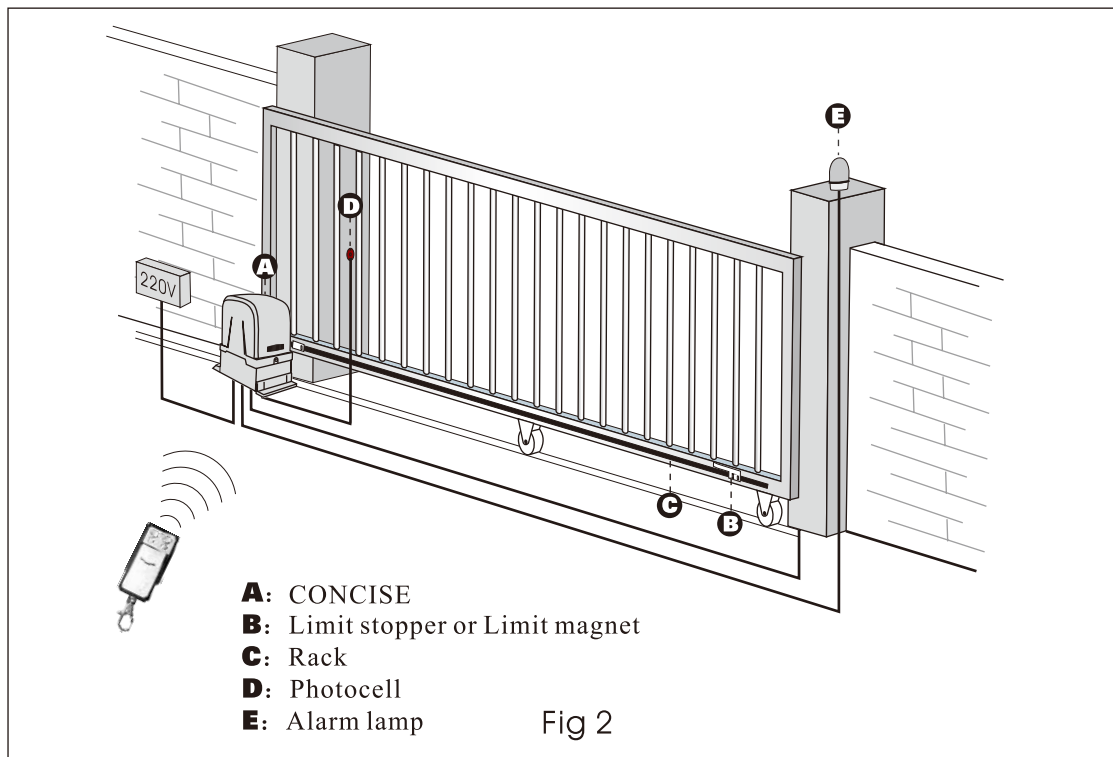

2.2 Installation and adjustment

2.2.1 Install baseplate on the ground, then, fasten the sliding motor on the baseplate.

Key: Ensure baseplate on level position.

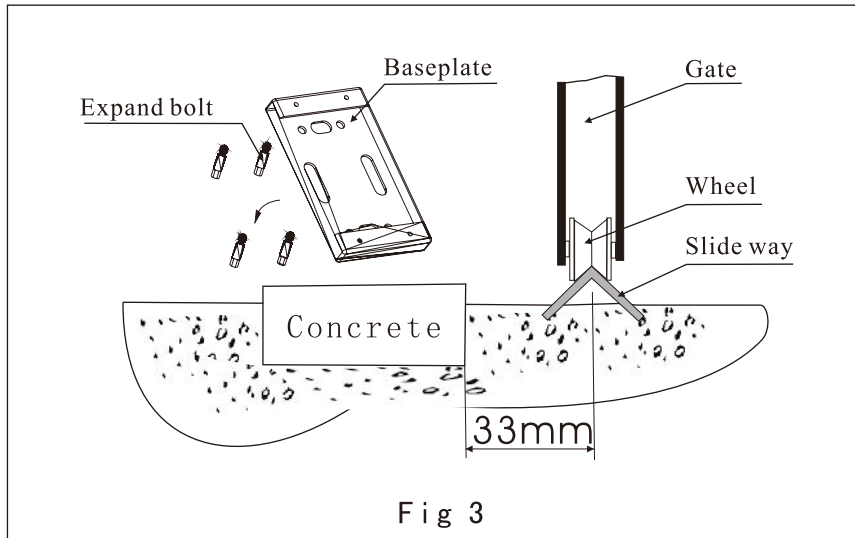

2.2.2 Install the limit stopper or limit magnet at proper position on the steel rack.

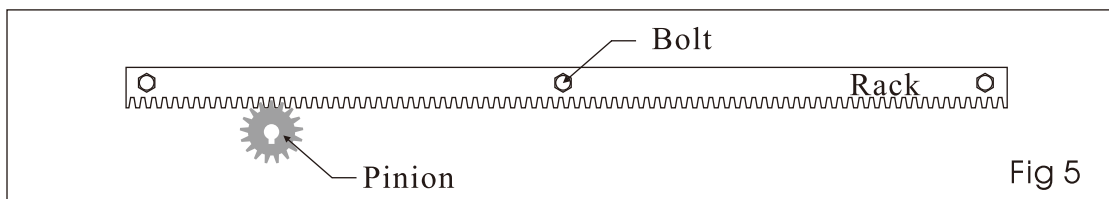
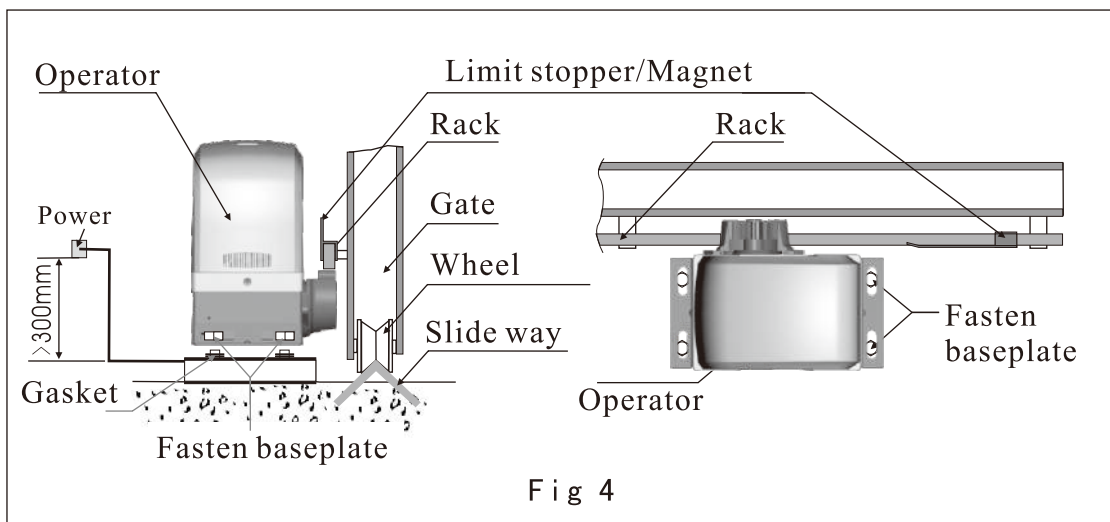

Before place the limit stopper or magnet on the rack, the gear box of the operator must be released. As per Fig 6 , Use the key turn clockwise to release the gear.

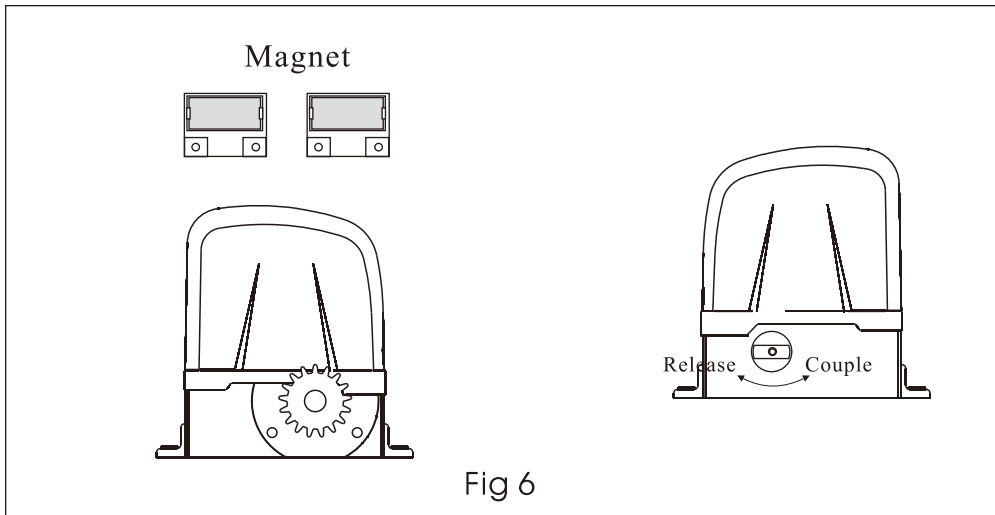

Move the gate manually to the open limit and close limit, mark the points on the Rack, then, fix the limit Stoppers or Magnets at the limit points on the Rack.

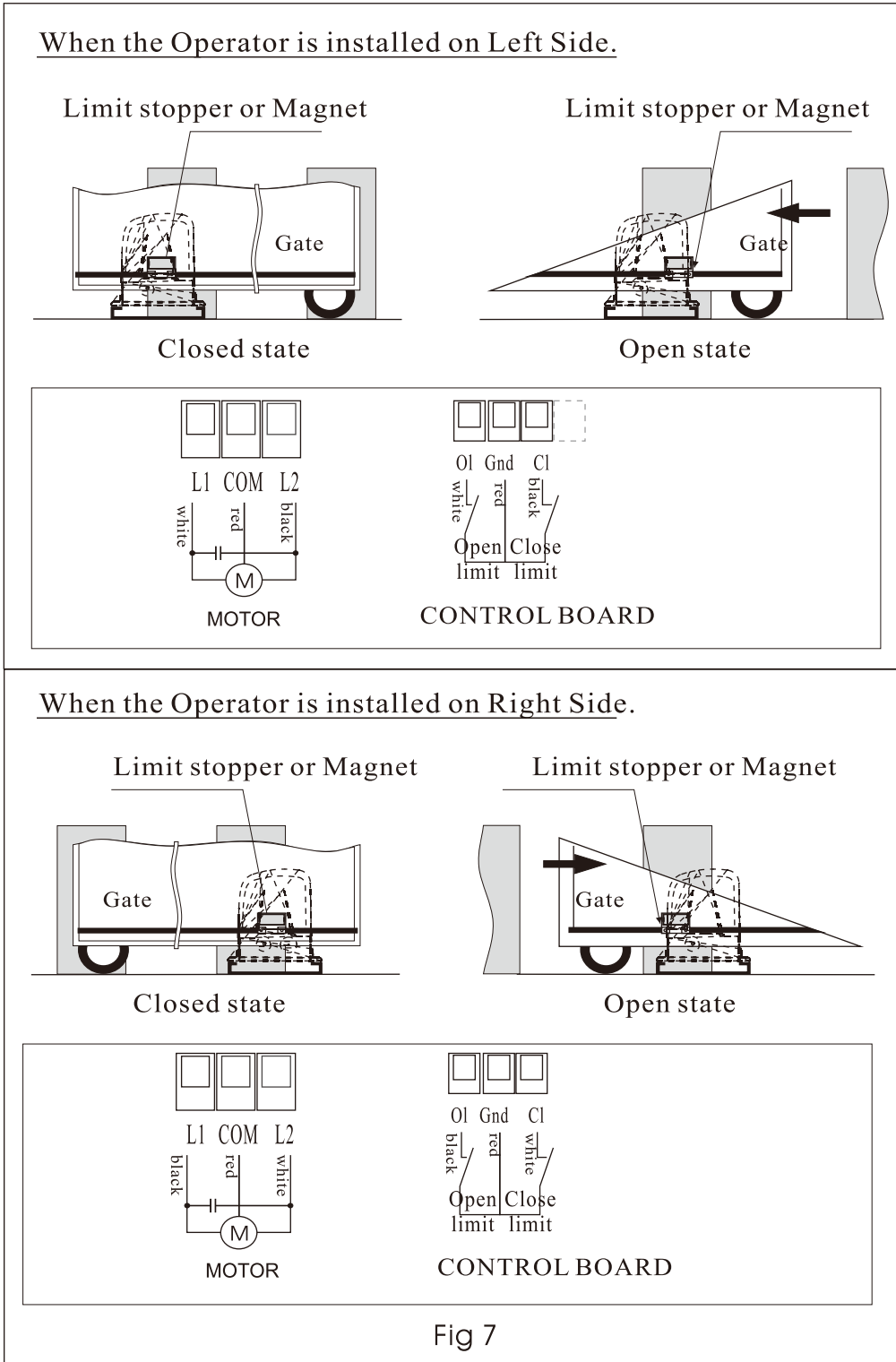

NOTE: Magnet must be 10mm~20mm space from the operator, and must be same height with the Magnetic switch inside of the Operator.

3. Control Board

Technical data

Power supply	230V 50/60Hz
Accessories power supply	AC15V 3W max
Operating temperature range	-20C~+55C
Pause time	1--100sec
Frequency	433Mhz

3.1 Layout of PCB and Definition

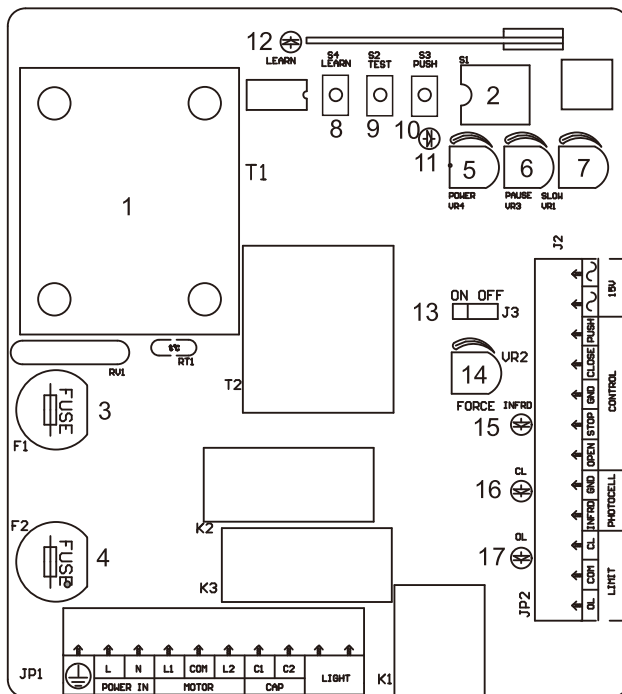

1. Transformer
2. DIP Switch
3. Fuse (0.2A)
4. Fuse (5A)
5. Trimmer for power regulation
6. Trimmer for pausing time
7. Trimmer for slowing power
8. Learn button
9. Test button
10. Push start button
11. Power Led
12. Learn Led
13. Jumper for reverse function
(ON: Valid)
14. Trimmer for resistance of obstacle
15. Photocell Led
16. Close limit Led
17. Open limit Led

3.2 Diagram

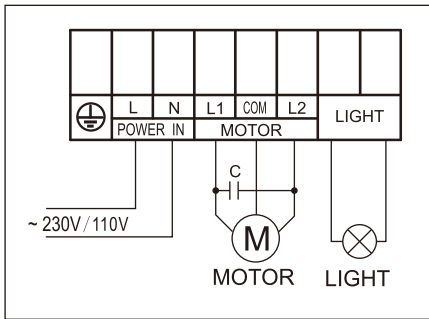

Wiring Diagram 1

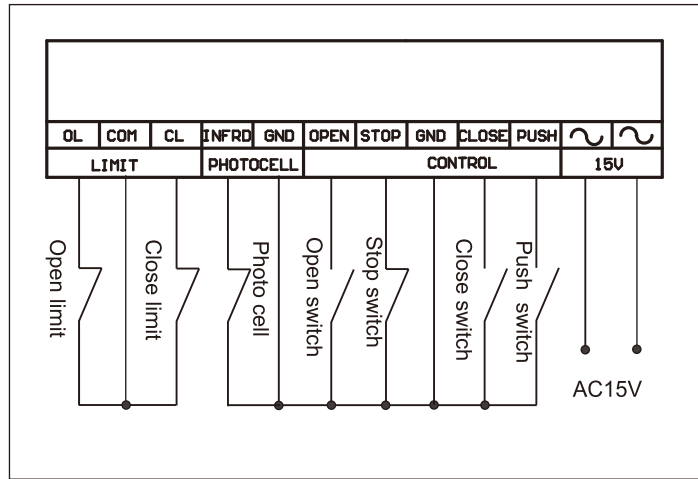

Wiring Diagram 2

3.3 DIP switch programming



DIP1:

ON: Enable auto-close

OFF: Disable auto-close

DIP2:

ON: Enable soft start

OFF: Disable soft start

DIP3:

ON: Enable soft stop

OFF: Disable soft stop

DIP4:

ON: Step by Step mode

OFF: No use



Vr4: Trimmer for motor power adjustment, it is used to avoid the gates moving at high speed towards the end of the opening and closing stages.

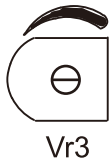

Vr3: Trimmer for pausing time, the gate's waiting time must be defined when it is in gate open limit status.



Vr1 : Trimmer for power adjustment of slowing status.

3.4 Running time programming

After finish the installing and connecting, Power on, and Press "Test" for 3 second, the gate will open and close at the limit point one cycle, the running time is remembered by the control system.

If no limit stopper or limit magnet on the rack, you also can press "Test" when the gate open and close to the right limit points.

3.5 Transmitter's code setting

Press "LEARN BUTTON", the "LEARN LED" light, then, press the button which you choose on the transmitter till the "LEARN LED" flash and go out, Now, the transmitter is coded. Other transmitters can be coded as this way

Specification maybe changed without a prior notification.

3.6 Erasing the transmitter's code

Erasing transmitter codes: Press "LEARN BUTTON" and hold on to make the "LEARN LED" light till go out. Now, all codes of transmitters which had been learnt are cleared.

4. Trouble Shooting

Number	Trouble	Cause	Shooting
1	motor can not work	<ul style="list-style-type: none"> *No power supply *Break fuse * capacitor decay *Surpass load *Effected by the thermal protection 	<ul style="list-style-type: none"> *Check power supply *Change fuse *Change capacitor *Check if any barrier on track *Restart after 20 minutes
2	Can open (close) but can not close (open)	<ul style="list-style-type: none"> *Position of limit switch is not correct *Limit switch is damaged *whether L1\COM\L2 wires are connected wrong *Magnetic-steel dropped and position isn't right 	<ul style="list-style-type: none"> *Adjust position *Change limit switch *Connect correctly according to wiring diagram *Re- adjust magnetic-steel position
3	can not locate accurately	<ul style="list-style-type: none"> *Distance of limit switch is too large * limit switch is *whether COM, CLOSE, OPEN were connected *magnetic-steel' s position is wrong 	<ul style="list-style-type: none"> * Adjust position of limit switch *Change limit switch *Connect correctly according to wiring diagram *Re-adjust the position
4	Release device	<ul style="list-style-type: none"> *Operating handle is broken * Worm gears are jammed 	<ul style="list-style-type: none"> *Change the handle *Rotate the pinion
5	Push the “open” button but the gate close	<ul style="list-style-type: none"> * whether L1\L2wires are connected wrong 	<ul style="list-style-type: none"> *Connect correctly according to wiring diagram
6	Motor can turn but can not work	<ul style="list-style-type: none"> * Compression spring of clutch is dead * Gear box is released 	<ul style="list-style-type: none"> * Change the spring * Couple the worm gear

www.smartpower.co.in service@smartpower.co.in

Help Line : +91 9831155801 / Toll FREE 8100 400 200